

HYDRASleeve

Simple by Design US Patents No. 6,481,300; No. 6,837,120; others pending

Field Manual

Introduction

The HydraSleeve groundwater sampler can be used to collect a representative sample for most physical and chemical parameters without purging the well. It collects a whole water sample from a user-defined interval (typically within the well screen), without mixing fluid from other intervals. One or more HydraSleeves are placed within the screened interval of the monitoring well, and a period of time is allocated for the well to re-equilibrate. Hours to months later, the sealed HydraSleeve can be activated for sample collection. When activated, HydraSleeve collects a sample with no drawdown and minimal agitation or displacement of the water column. Once the sampler is full, the one-way reed valve collapses, preventing mixing of extraneous, non-representative fluid during recovery.

Assembly

Assembling the HydraSleeve is simple, and can be done by one person in the field, taking only a minute or two.

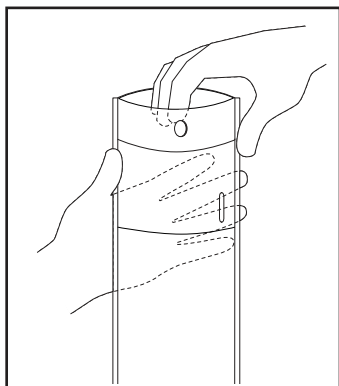

1 Remove HydraSleeve from package and grasp top to "pop" open.

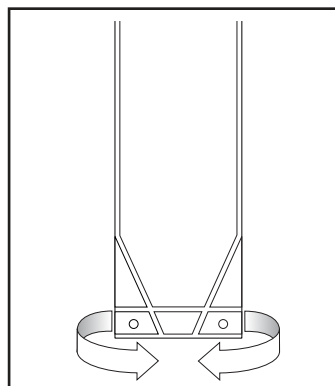

4 Fold the two holes at bottom of HydraSleeve together and attach weight

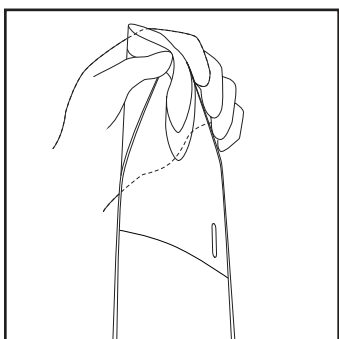

2 Squeeze side fins together at top to bend reinforcing strips outward.

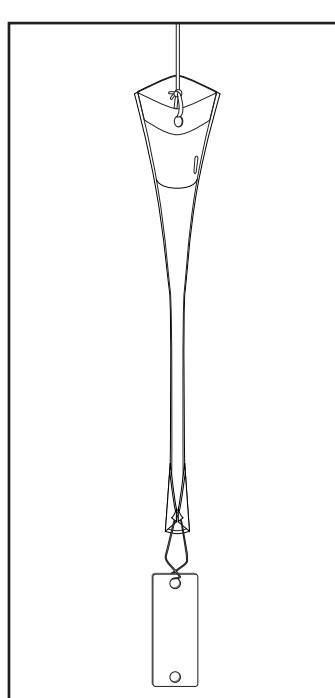

5 Sampler is ready to insert into the well.

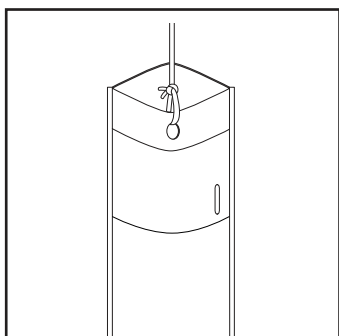

3 Attach line to hole at top of HydraSleeve.

Placing the HydraSleeve(s)

To collect a representative groundwater sample without purging, the well must be allowed time to re-equilibrate after placement of the sampler. When any device is lowered into a well, some mixing of the water column occurs. The diameter of the device and its shape greatly affect the degree of mixing. The flat cross-section of the empty HydraSleeve minimizes the disturbance to the water column as the sampler is lowered into position, reducing the time needed for the well to return to equilibrium.

There are three basic methods for holding a HydraSleeve in position as the well equilibrates.

TOP DOWN DEPLOYMENT (Figure 1)

Measure the correct amount of suspension line needed to "hang" the top of the HydraSleeve(s) at the desired sampling depth (in most cases, this will be at the bottom of the sampling zone). The upper end of the tether can be connected to the well cap to suspend the HydraSleeve at the correct depth until activated for sampling.

Note: For deep settings, it may be difficult to accurately measure long segments of suspension line in the field. Factory prepared, custom suspension line and attachment points can be provided.

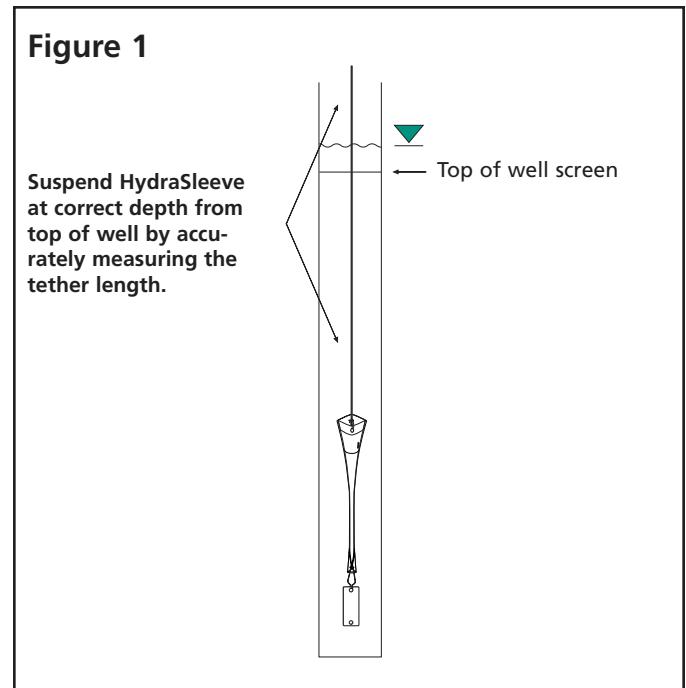

BOTTOM DEPLOYMENT (Figure 2)

Sound the well to determine the exact depth. Lower the weighted HydraSleeve into the well and let it touch the bottom. Very slowly (less than 1/2 foot per second) raise the sampler to the point where the check valve is at the depth the sample is to be collected. Attach the suspension line to the top of the well to suspend it at this depth. (It is often easier to measure a few feet from the bottom of the well up to the sample point, than it is to measure many feet from the top of the well down.)

Alternately, the sampler can be left on the bottom until the well re-equilibrates. For sampling, it can be very slowly pulled (< 1/2 fps) to sampling depth, then activated (see "Sample Collection," p. 6) to collect the sample, and retrieved to the surface.

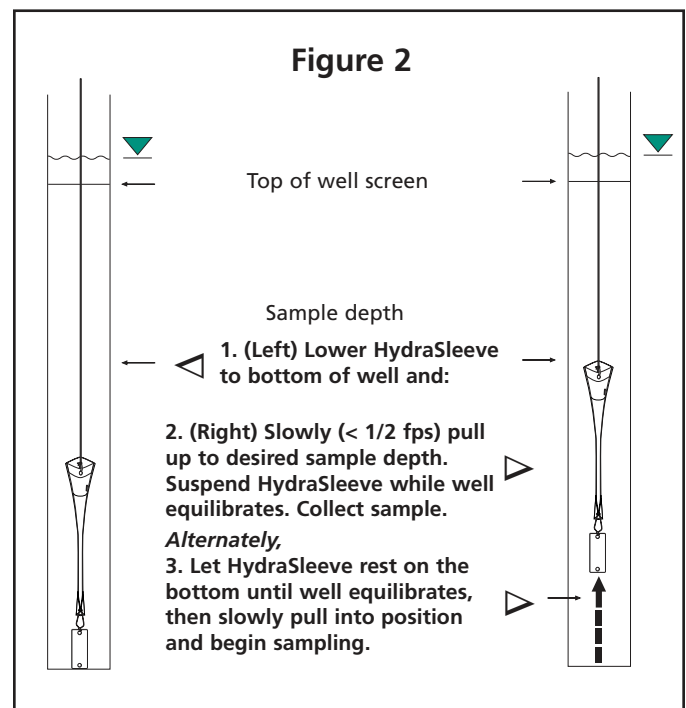

BOTTOM ANCHOR (Figure 3)

Determine the exact depth of the well.
Calculate the distance from the bottom of the well to the desired sampling depth.
Attach an appropriate length anchor line between the weight and the bottom of the sampler and lower the assembly until the weight rests on the bottom of the well, allowing the top of the sampler to float at the correct sampling depth.

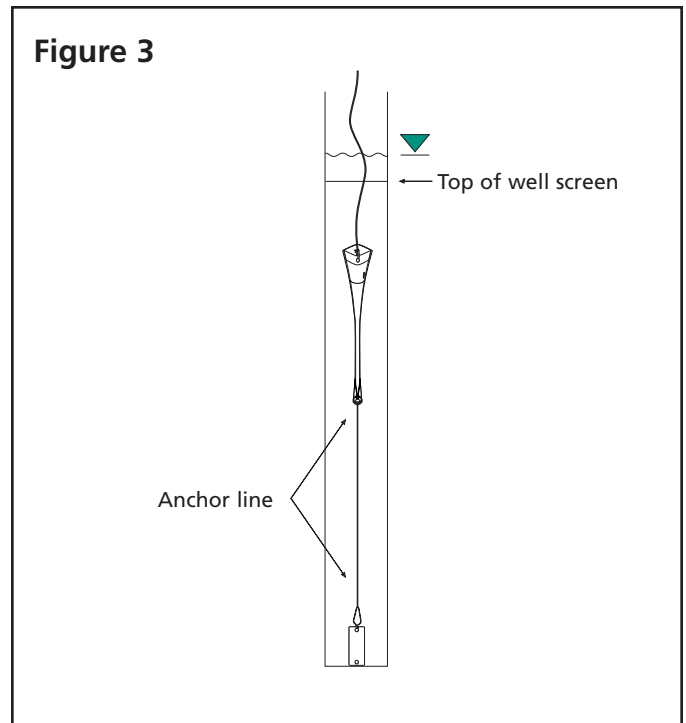

Multiple Interval Deployment

There are two basic methods for placing multiple HydraSleeves in a well to collect samples from different levels simultaneously.

ATTACHED TO A SINGLE TETHER (Figure 4)

To use 3 or more samplers simultaneously, we recommend attaching them all to a tether for support to prevent the sampling string from pulling apart. The weight is attached to a single length of suspension line and allowed to rest on the bottom of the well. The top and bottom of each HydraSleeve are attached to the tether at the desired sample intervals. Cable tie or stainless steel clips (supplied) work well for attaching the HydraSleeves to the line. Simply push one end of the clip between strands of the rope at the desired point before attaching the clip to the HydraSleeve.

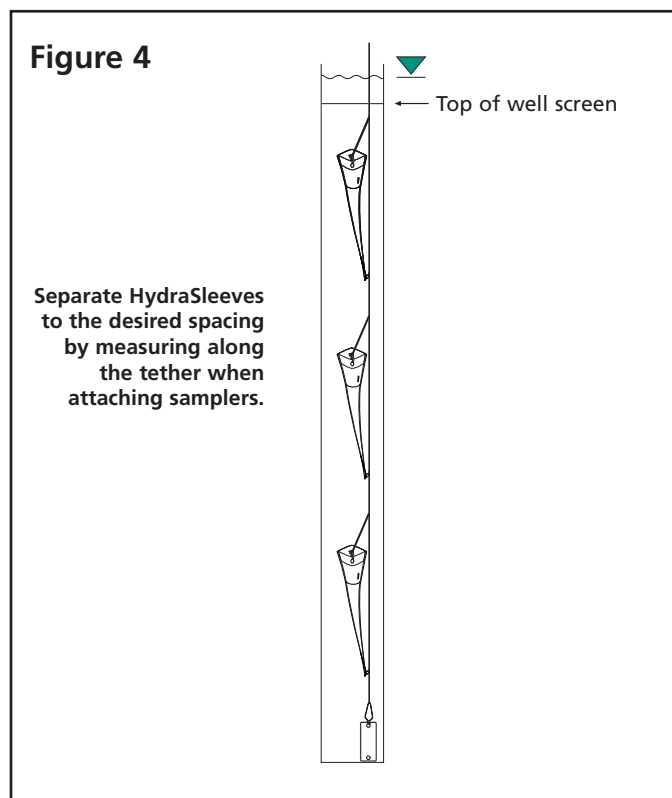

ATTACHED END TO END (Figure 5)

To place 2 or 3 stacked HydraSleeves for vertical profiling, use one of the methods described above to locate the bottom sampler. Attach the bottom of the top sampler to the top of the following HydraSleeve(s) with a carefully measured length of suspension cable. Connect the weight to the bottom sampler. Note: if many HydraSleeves are attached to a tether, more weight may be required than with a single sampler.

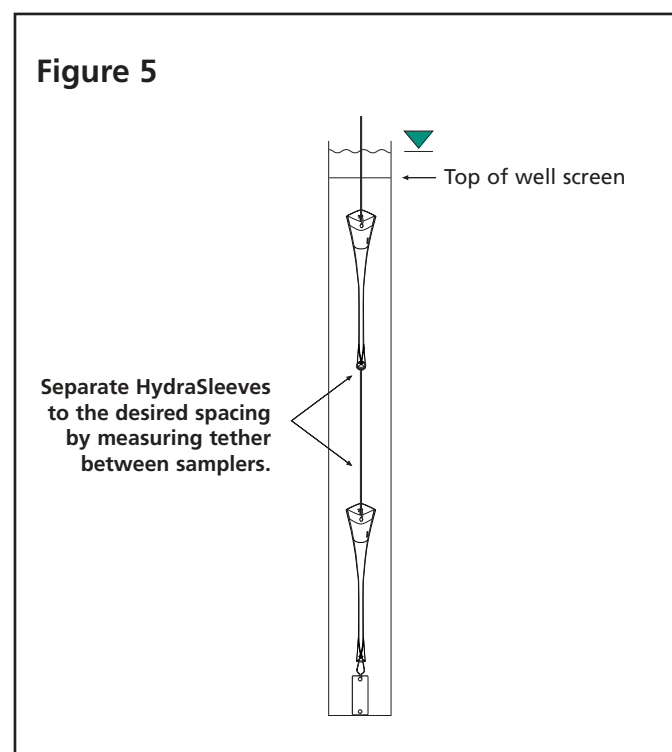

Sample Collection

The HydraSleeve must move upward at a rate of one foot per second or faster (about the speed a bailer is usually pulled upward) for water to pass through the check valve into the sample sleeve. The total upward distance the check valve must travel to fill the sample sleeve is about 1 to 2 times the length of the sampler. For example, a 24-inch HydraSleeve needs a total upward movement of 24 to no more than 48 inches to fill. The upward motion can be accomplished using one long continuous pull, several short strokes, or any combination that moves the check valve the required distance in the open position. A special technique is used for sampling low-yield wells.

CONTINUOUS PULL (Figure 6)

Pull the HydraSleeve continuously upward from its starting point at a constant 1 to 2 feet per second until full. This method usually provides the least turbid samples and is analogous to coring the water column from the bottom up.

Note: When using this method, the screen interval should be long enough so the sampler fills before exiting the top of the screen.

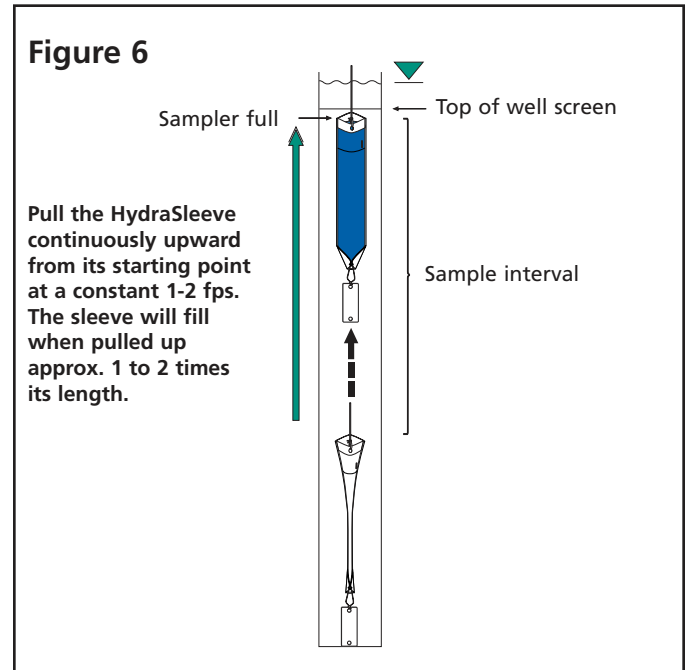

SHORT STROKES (Figure 7)

Pull the sampler upward at about 1 to 2 feet per second for the length of the sampler and let it drop back to the starting point. Repeat the cycle 3 to 5 times.

This method provides a shorter sampling interval than the continuous pull method (above), and usually reduces the turbidity levels of the sample below that of numerous rapid, short cycles (below). The sample comes from between the top of the cycle and the bottom of the sampler at its lowest point.

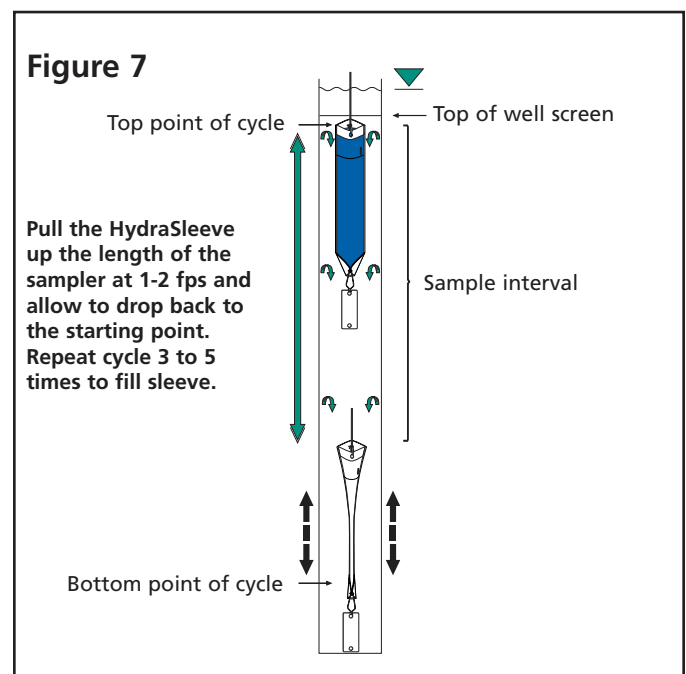

RAPID, SHORT CYCLES (Figure 8)

Cycle the HydraSleeve up and down using rapid, short strokes (6-inch cycle at a minimum of 1 cycle per second) 5 to 8 times. This method provides the shortest sampling interval. Dye studies have shown that when using this method the sample flows into the check valve from along the length of the sampler and immediately above the check valve. The sample interval is from the bottom the sampler at its lowest point in the cycle to the top of the check valve at the peak of the cycle.

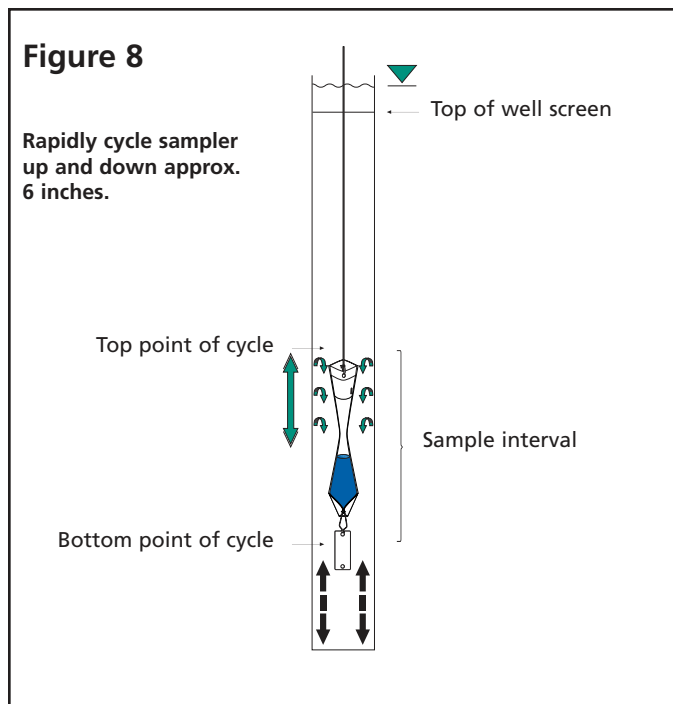

SAMPLING LOW-YIELD WELLS (Figure 9)

HydraSleeve provides the best available technology for sampling low yield wells. When pulled upward after the well re-equilibrates, the HydraSleeve will collect a water core from the top of the sampler to about its own length above that point. The sample is collected with no drawdown in the well and minimal sample agitation. An optional top weight can be attached to compress the sampler in the bottom of the well if needed for an extremely short water column. With a top weight, the check valve is pushed down to within a foot of the bottom of the well.

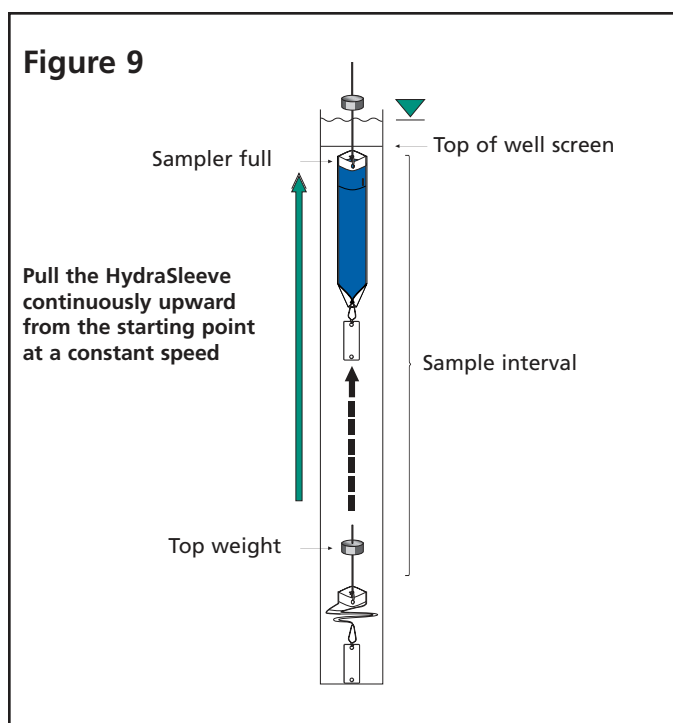

Sample Discharge

The best way to remove a sample from the HydraSleeve with the least amount of aeration and agitation is with the short plastic discharge tube (included).



First, squeeze the full sampler just below the top to expel water resting above the flexible check valve. (Photo 1, top left)

Then, push the pointed discharge tube through the outer polyethylene sleeve about 3-4 inches below the white reinforcing strips. (Photo 2, middle left)

Discharge the sample into the desired container. (Photo 3, bottom left)



Raising and lowering the bottom of the sampler or pinching the sample sleeve just below the discharge tube will control the flow of the sample. The sample sleeve can also be squeezed, forcing fluid up through the discharge tube, similar to squeezing a tube of toothpaste. With a little practice, and using a flat surface to set the sample containers on, HydraSleeve sampling becomes a one-person operation.



EON

Distributed by: **PRODUCTS, INC.** 800-474-2490
www.eonpro.com